

① Laser light source

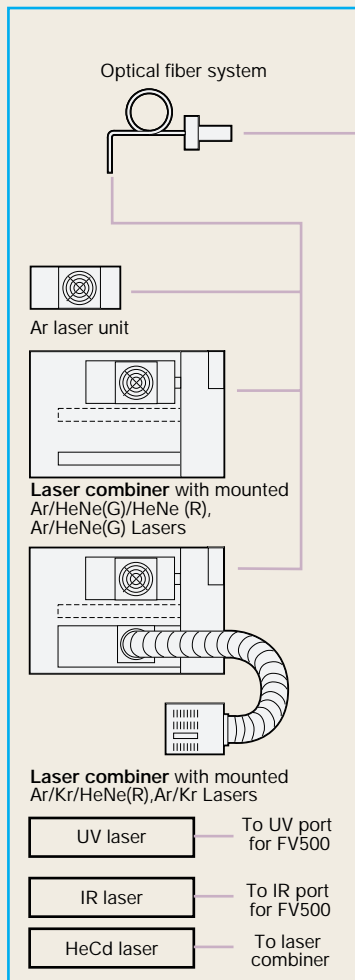

② Scanning unit

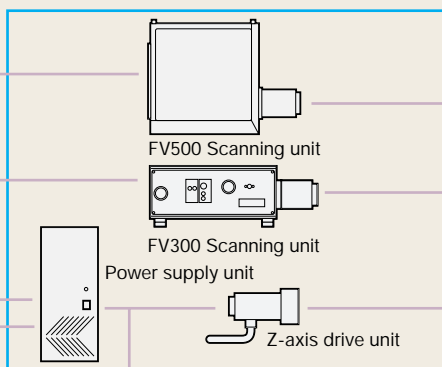

④ Transmitted light detector system

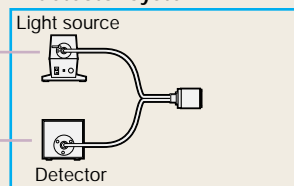

⑤ Fluorescence illumination system

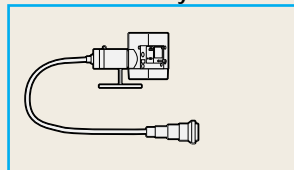

External trigger (IN/OUT)

⑥ PC system with control boards



③ Microscopes

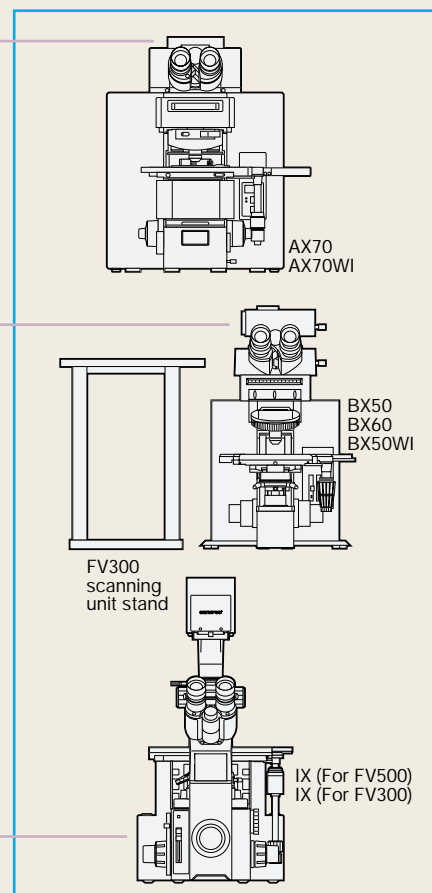

⑦ Fluoview application software

